

ระบบป้องกันตะกรัน และ แบคทีเรีย

- APEF เป็นอุปกรณ์อิเล็กทรอนิกส์แรกและหนึ่งเดียวสำหรับการบำบัดน้ำดื่มสำหรับใช้ในครัวเรือน และอุตสาหกรรม พร้อมคุณสมบัติป้องกันตะกรันและต้านเชื้อแบคทีเรีย
- APEF ทำงานโดยการสร้างสนามไฟฟ้าพัลส์ความเข้มสูงมาก (PEF - Alfa water Pulsed Electric field) เปลี่ยนแคลเซียมคาร์บอเนตเป็นอารากอนไนต์ โดยไม่เปลี่ยนแปลงคุณสมบัติทางเคมีอันทรีย์
- APEF คงรักษาสารแร่ธาตุทั้งหมดในสภาพแขวนลอย ป้องกันการก่อตัวของคราบตะกรัน และผลข้างเคียงเชิงลบที่เกี่ยวข้อง



APEF BENEFITS

- APEF เป็นมิตรต่อสิ่งแวดล้อมอย่างยั่งยืน (Eco-sustainable)
- APEF ขจัดและป้องกันการสะสมของคราบหินปูน
- APEF กำจัดและป้องกันแบคทีเรีย เชื้อรา สาหร่าย และอื่นๆ
- APEF รักษาแนวท่อทั้งหมด
- APEF ช่วยลดต้นทุนการบำรุงรักษาระบบสุขาภิบาลและความร้อน
- APEF รักษาเกลือแร่ต่าง ๆ ในน้ำดื่มไว้ได้
- APEF ยืดอายุการใช้งานของเครื่องใช้ในครัวเรือน
- APEF เพิ่มค่า pH โดยการสร้างน้ำอัลคาไลน์และส่งเสริมการฟื้นฟูเซลล์
- APEF ช่วยประหยัดการใช้น้ำยาซักล้างสำหรับใช้ในครัวเรือน
- APEF สามารถตรวจสอบความกระด้างของน้ำได้แบบเรียลไทม์ และตั้งค่าพลังงานที่เหมาะสมที่สุดโดยอัตโนมัติ ทำให้ประหยัดพลังงานได้อย่างมาก
- APEF ทำงานได้แม้หลังจากที่น้ำร้อนแล้ว ทำให้ระบบมีประสิทธิภาพ แม้สำหรับถังเก็บน้ำหรือการผลิตน้ำร้อนแบบทันที (สูงถึง 65 องศาเซลเซียส)
- ลดค่าใช้จ่ายในการซ่อมแซมและเปลี่ยนชิ้นส่วน
- ลดการใช้พลังงานในการทำน้ำร้อน
- ต่อด้านการก่อตัวของสภาพแวดล้อม (คราบหินปูน) ที่เอื้อต่อการเจริญเติบโตของแบคทีเรียในระบบน้ำ





PATENTED

APEF Alfawater Pulsed Electric Field

02/2025

ARAGON È IL PRIMO FILTRO BREVETTATO CHE PRODUCE UN CAMPO ELETTRICO PULSATO NELL'ACQUA CON FUNZIONI ANTIBATTERICHE E ANTICALCARE
ARAGON IS THE FIRST PATENTED FILTER GENERATING A PULSED ELECTRIC FIELD IN WATER WITH ANTIBACTERIAL AND DE-SCALING FUNCTIONS

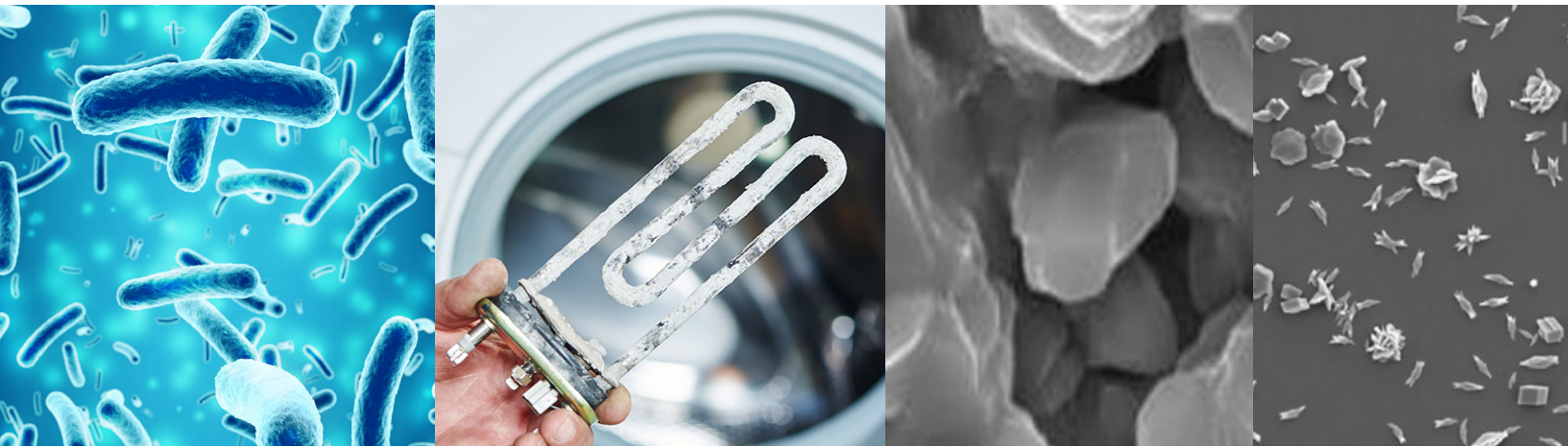

L'utilizzo della tecnologia PEF (Pulsed Electric Field), è nata nell'industria alimentare per la capacità di ridurre la presenza di microrganismi negli alimenti. Il nostro reparto di R&D ha sviluppato la generazione di un campo elettrico variabile ad alta frequenza in acqua, ottenendo due effetti significativi: impedisce la precipitazione del carbonato di calcio nella forma cristallina di Calcite, favorendo invece la sua permanenza in una forma amorfa e più idrosolubile, promuovendo la formazione di nano-cristalli di Aragonite che, a causa della loro struttura, non si aggregano sottoforma di incrostazioni, ma vengono piuttosto trascinati via dal flusso dell'acqua.

Il trattamento con campo elettrico pulsato (PEF) può essere utilizzato con successo per il controllo della crescita del biofilm nell'acqua: i microrganismi vengono disattivati mediante l'elettroporazione della membrana cellulare. Il risultato è che all'accensione di ARAGON si riduce immediatamente la carica microbica e la crescita del biofilm.

The use of PEF (Pulsed Electric Field) was born in the food industry for its ability to reduce the presence of microorganisms in foods. Our R&D department has developed the generation of a variable high-frequency electric field, obtaining two significant effects: it prevents the precipitation of calcium carbonate in the crystalline form of Calcite, instead promoting its permanence in an amorphous and more water-soluble form, promoting the formation of Aragonite nano-crystals which do not aggregate into deposits, but are rather carried away by the water flow.

The treatment with Pulsed Electric Field (PEF) can be successfully used for the control of biofilm growth in water: microorganisms are deactivated through electroporation of the cell membrane. The outcome is an immediate reduction in microbial load and biofilm growth upon activation of ARAGON.

Buoni motivi per utilizzare ARAGON

- Il filtro ARAGON è facilmente installabile anche in circuiti esistenti ad uso civile, industriale, ricreativo e sanitario.
- L'azione erosiva dell'aragonite scrosta i depositi calcarei dall'interno delle tubazioni, dagli scambiatori di calore, per uso domestico e industriale.
- Il sistema di generazione ARAGON non richiede alcuna manutenzione.
- Assorbimento elettrico bassissimo, anche in caso di acque molto dure.
- Risparmio economico legato al minor spreco di energia, alla riduzione nel consumo di prodotti per pulizia, alla maggior durata delle apparecchiature e alla diminuzione delle spese di manutenzione.

Good reasons to use ARAGON

- *The ARAGON filter can be easily installed in existing residential, industrial, wellness and healthcare circuits.*
- *The erosive action of aragonite removes limescale deposits from the inside of the pipes, from the heat exchangers, from the heating elements and pumps of both household appliances and industrial machines.*
- *The ARAGON generation system does not require any maintenance.*
- *Very low electrical absorption, even in the case of very hard water.*
- *Economic savings linked to less waste of energy, reduction in the consumption of cleaning products, longer life of the equipment and reduction in maintenance costs.*

Filtro ARAGON per uso civile

ARAGON filter for civil use

ARAGON è un sistema tecnologicamente avanzato e brevettato, specificatamente studiato per ottimizzare la qualità dell'acqua potabile, sia in contesti civili che industriali.

La particolarità di questo sistema risiede nelle sue proprietà di anticalcare, imputabili all'utilizzo della Tecnologia dei Campi Elettrici Pulsati (PEF).

Questa soluzione tecnologica permette ad ARAGON di fornire acqua di livello qualitativo superiore.

Il sistema ARAGON è composto da due parti fondamentali: una centralina elettronica e un filtro con due elettrodi realizzati di forma particolare e brevettata.

ARAGON is a technologically advanced and patented system, specifically designed for optimizing the quality of drinking water, both in civil and industrial contexts.

The distinction of this system lies in its anti-scaling properties, attributable to the use of Pulsed Electric Fields (PEF) Technology.

This technological solution allows ARAGON to provide water of a superior quality level.

The ARAGON system consists of two main components: an electronic control unit and a filter with two uniquely designed, patented electrodes.



Principio di funzionamento e utilizzo:

Operativamente, ARAGON è progettato per preservare un'ampia gamma di circuiti idronici – compresi quelli dedicati all'acqua per uso sanitario, sia calda che fredda, e quelli per l'acqua destinata a scopi tecnici e tecnologici – impedendo sia la proliferazione batterica che l'accumulo di depositi calcarei.

Grazie all'emissione di un campo elettrico variabile ad alta frequenza, il sistema induce due effetti significativi: da un lato impedisce la precipitazione del carbonato di calcio nella forma cristallina di calcite, favorendone invece la permanenza in ambiente amorfo e più solubile in acqua; dall'altro favorisce la formazione di nanocristalli di Aragonite che, per la loro struttura, non si aggregano in depositi, ma vengono piuttosto trascinati via dal flusso dell'acqua.

Questo processo è allo stesso tempo ecologico e naturale, rispettando l'integrità della composizione chimica dell'acqua trattata e preservando la concentrazione di sali naturali.

ARAGON può essere utilizzato in molteplici settori, ovunque sia necessario impedire la proliferazione batterica e la formazione di depositi calcarei senza alterare le proprietà chimiche dell'acqua.

La trasformazione in cristalli di Aragonite o calcite amorfa, che non portano alla formazione di depositi, mantiene la sua stabilità anche quando l'acqua è sottoposta a riscaldamento.



Questa caratteristica rende questo sistema particolarmente efficace in diversi contesti, tra cui serbatoi di accumulo e sistemi per la generazione immediata di acqua calda ad alta temperatura.

Operating Principle and Use:

Operationally, ARAGON is designed to preserve a wide range of hydronic circuits – including those dedicated to water for sanitary use, both hot and cold, and those for water intended for technical and technological purposes – by preventing both bacterial proliferation and the accumulation of limestone deposits.

Thanks to the emission of a variable high-frequency electric field, the system induces two significant effects: on one hand, it prevents the precipitation of calcium carbonate in the crystalline form of Calcite, instead promoting its permanence in an amorphous and more water-soluble; on the other, it promotes the formation of Aragonite nano-crystals which, due to their structure, do not aggregate into deposits, but are rather carried away by the water flow.

This process is both ecological and natural, respecting the integrity of the chemical composition of the treated water and preserving the concentration of natural salts.

ARAGON can be used in a multitude of sectors, wherever it is necessary to prevent bacterial proliferation and the formation of limestone deposits without altering the chemical properties of the water.

The transformation into Aragonite or amorphous calcite crystals, which do not lead to the formation of deposits, maintains its stability even when the water is subjected to heating.

This characteristic makes this system particularly effective in various contexts, including storage tanks and systems for the immediate generation of high-temperature hot water.

APEF è disponibile in 2 modelli:

APEF is available in 2 models:

CARATTERISTICHE FEATURES	ARG K10	ARG K20
Portata massima nominale (Qn) 3/4" Nominal maximum flow rate (Qn) 3/4"	2,4 m³/h	2,4 m³/h
Portata massima nominale (Qn) 1" Nominal maximum flow rate (Qn) 1"	3,6 m³/h	5,0 m³/h
Portata massima nominale (Qn) 1" 1/2 Nominal maximum flow rate (Qn) 1" 1/2	5,2 m³/h	10,0 m³/h
Perdita di carico (ΔP) Pressure drop (ΔP)	0,2 Bar	
Pressione massima di esercizio Maximum working pressure	10 Bar	
Temperatura di esercizio (Tmin-Tmax) Operating temperature (Tmin-Tmax)	4° ÷ 45°C	
Umidità ambientale (Umax) a 31°C Ambient humidity (Umax) @ 31°C	80 %	
Temperatura max acqua trattata (Tmax) Max treated water temperature (Tmax)	65°C	
Gradi di filtrazione Filtration degree	1 μm ÷ 50 μm	
Alimentazione elettrica Electrical supply	220-240-110 VAC	
Alimentazione elettrica Electrical supply	50-60 Hz	
Assorbimento elettrico massimo (Wmax) Maximum electrical absorption (Wmax)	20 W	
Corrente max assorbita (Imax) Maximum absorbed current (Imax)	0,07 A	
Grado di protezione elettrica (IP) Degree of electrical protection (IP)	IP 44	
Altezza nominale unità idraulica (A) Nominal height of hydraulic unit (A)	10"	20"
Raccordi In/Out Fittings In/Out	3/4" / 1" / 1"1/2	3/4" / 1" / 1"1/2
Peso a vuoto (P) Empty weight (P)	2,4 Kg	2,8 Kg

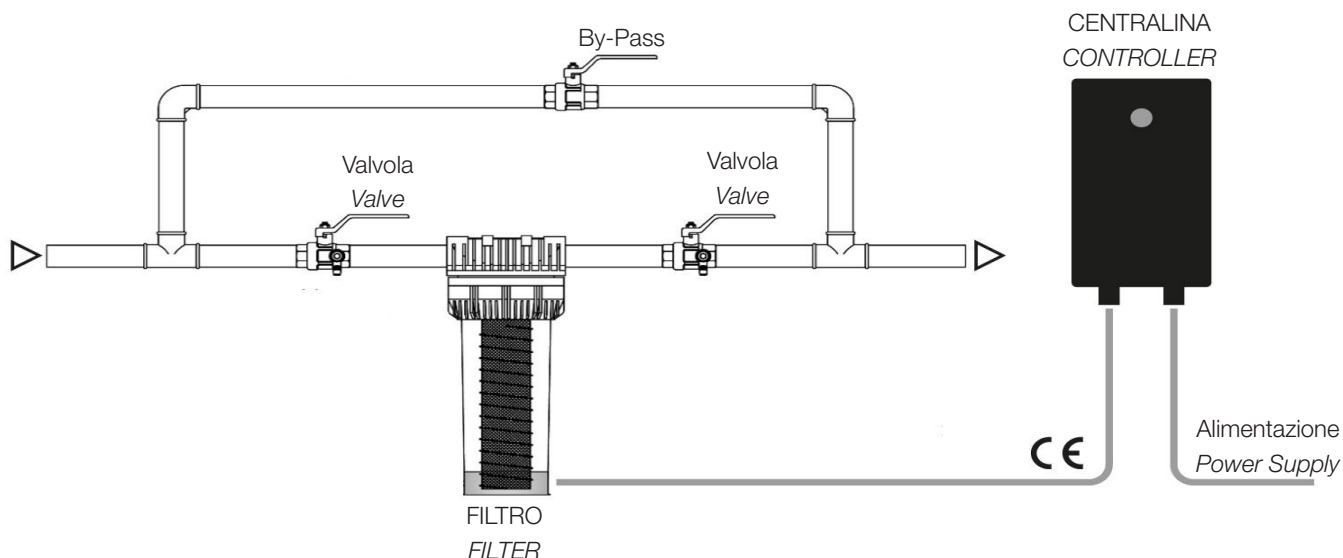

Filtro ARAGON-HF per grandi portate: *ARAGON-HF filter for high flow rates:*

Alfa Water ha sviluppato un sistema brevettato ARAGON-HF in grado di generare il campo elettrico pulsato per grandi portate (da 10 m³/h a 1000 m³/h) creato per ottimizzare la qualità dell'acqua con funzione anticalcare e per il controllo della proliferazione microbica.

Il sistema è costituito da un recipiente contenente un fascio tubiero opportunamente progettato in grado di generare, attraverso un apposito quadro di controllo e potenza, un efficace ed omogeneo campo elettrico pulsato in acqua.

Alfa Water has developed a patented ARAGON-HF system capable of generating the pulsed electric field for large flow rates (from 10 m³/h to 1000 m³/h) created to optimize the quality of the water with anti-limescale function and to control microbial proliferation.

The system consists of a vessel containing a suitably designed tube bundle capable of generating, through a special control and power panel, an effective and homogeneous electric field pulsed in water.

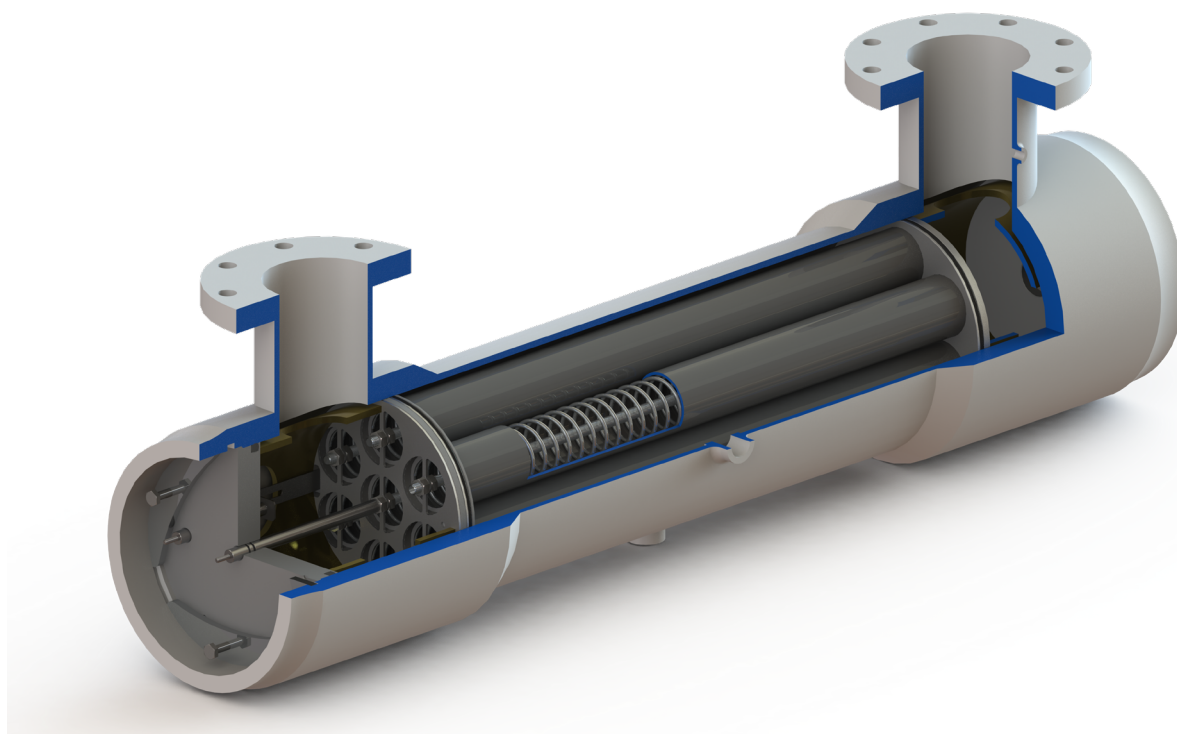

Modelli di impianti Aragon HP: *ARAGON HF system models:*

MODELLI MODELS	In/out [min-max flow rate]	Min-Max flow rate	L x W x H (mm)
2-ARG HF6	6"	140 mc/h	1400 x 1100 x 650
4-ARG HF6	6"	280 mc/h	1400 x 1100 x 960
6-ARG HF8	8"	420 mc/h	1400 x 1100 x 1270
8-ARG HF10	10"	560 mc/h	1400 x 1100 x 1580
10-ARG HF10	10"	700 mc/h	1400 x 1100 x 1890



APPLICAZIONI:

Sistemi di potabilizzazione
 Settore ospedaliero
 Food & Beverage
 Piscine
 Wellness
 Acqua di pozzo, fiume, lago
 Riutilizzo acque di scarico
 Acqua industriale di processo
 Torri di raffreddamento
 Protezione RO
 Settore agricolo
 Irrigazione
 Settore Ittico
 Fattorie
 Circuiti termosanitari

APPLICATIONS:

- Potabilization systems
- Healthcare sector
- Food & Beverage
- Pools
- Benessere
- Well, river, lake water
- Industrial process water
- Water reuse
- Cooling towers
- RO protection
- Agricultural sector
- Irrigation
- Fish farms
- Farms
- Thermo-sanitary circuits



ESEMPI APPLICATIVI DEI FILTRI ARAGON: Tecnologia Alfacleaner

APPLICATION EXAMPLES OF ARAGON FILTERS: Alfacleaner Technology

Alfa Water propone la sua gamma di sistemi integrati Alfacleaner, composti da un filtro automatico AVC e filtro ARAGON, oppure filtro a sacco ABG con magnete e filtro ARAGON.

Alfa Water offers its range of integrated systems, Alfacleaner, comprised of an automatic AVC filter and ARAGON filter, or ABG bag filter with magnet and ARAGON filter.

Circuiti idronici chiusi

Nei circuiti termici chiusi l'efficienza e la conservazione di tubazioni, valvole e apparecchiature sono di fondamentale importanza. Nonostante ciò, l'acqua in essi contenuta produce depositi e cresce il biofilm, favorendo così l'insorgere di gravi inconvenienti come:

- corrosioni;
- formazione di depositi ed incrostazioni;
- calo delle prestazioni;
- aumento dei costi di manutenzione;
- fermi impianto imprevisti;
- riduzione della vita media degli impianti.

Grazie all'utilizzo del sistema Alfacleaner con filtro a sacco ABG dotato di magnete e di filtro ARAGON è possibile pulire completamente il circuito termico, ottimizzando l'aggiunta di prodotti chimici.

Closed hydronic circuits

In the thermal closed circuits, the efficiency and conservation of pipelines, valves and equipment's are of fundamental importance. Despite this, the water contained in them produces deposits and biofilm grows, thus favouring the onset of serious problems such as:

- *corrosions;*
- *formation of deposits and scale;*
- *decline in performances;*
- *increased of maintenance costs;*
- *unexpected plant outages;*
- *reduction in the average life of the plants.*

Thanks to the use of the Alfacleaner system with ABG bag filter equipped with a magnet and ARAGON filter, it is possible to completely clean the thermal circuit optimizing the chemicals dosing.



I VANTAGGI DELLA TECNOLOGIA ALFACLEANER

THE ADVANTAGES OF ALFACLEANER TECHNOLOGY

	Flusso laterale/Flusso completo Side stream / Full stream (on-line)	Trattamenti tradizionali Traditional treatments
È richiesto il fermo impianto <i>Plant shutdown is required</i>	NO	YES
È un trattamento economico <i>It is an economic treatment</i>	YES	NO
È necessario lo smaltimento dei reflui <i>Waste disposal is necessary</i>	NO	YES
Strumento di facile applicazione ed installazione <i>Easy application and installation tool</i>	YES	NO
Nessun utilizzo di prodotti chimici <i>No use of chemical products</i>	YES	NO
Rischio per gli operatori <i>Risk for operators</i>	NO	YES

ALFAWATER CLEANER TECNOLOGIA PEF ALFAWATER CLEANER PEF TECHNOLOGY

Altri vantaggi della tecnologia Alfacleaner per i circuiti termici:

- Consente la riduzione degli interventi di manutenzione.
- Permette il recupero dell'efficienza termica, rimuovendo il biofilm e i fanghi.
- Migliora l'efficienza degli interventi di inibizione e passivazione.
- Applicabile in circuiti anche particolarmente compromessi, con o senza presenza di glicole.
- Adattabile su circuiti civili o industriali.

Other advantages of Alfacleaner technology for thermal circuits:

- *Allows the reduction of maintenance interventions.*
- *Allows the recovery of thermal efficiency, removing biofilm and sludge.*
- *Improves the efficiency of inhibition and passivation interventions.*
- *Suitable in particularly compromised circuits, with or without the presence of glycol.*
- *Adaptable on civil or industrial circuits.*

CONDIZIONI OPERATIVE PER L'UTILIZZO DI ALFACLEANER PER LA PULIZIA DEI CIRCUITI TERMICI

OPERATING CONDITIONS FOR THE USE OF ALFACLEANER FOR CLEANING THERMAL CIRCUITS

Alfacleaner è un sistema di pulizia dei circuiti termici composto di due stadi di filtrazione: il primo composto da filtro a sacco con il magnete (può essere dotato anche di più magneti) con filtrazioni disponibili di 1-5-10-25-50-100 micron) e un secondo stadio composto dal rivoluzionario filtro ARAGON che utilizza campi elettrici pulsati in acqua.

Il primo stadio cattura tutte le particelle solide comprese le particelle ferrose che aderiscono al magnete e le incrostazioni e il biofilm che viene staccato dal circuito idraulico in continuazione grazie all'azione del filtro aragon.

Il Filtro ARAGON è in grado di ottenere i seguenti effetti: la conversione della Calcite che forma calcare in nanocristalli di Aragonite, che non si aggregano in depositi, ma essendo cristalli di notevole durezza producono un effetto scrubber di tutto il circuito pulendolo dalle incrostazioni e dal biofilm già presente. Tutti i depositi e il biofilm distaccato vengono raccolti continuamente dal filtro a sacco, mentre l'acqua che passa nel sistema di filtrazione ARAGON viene continuamente filtrata con l'azione sinergica del campo elettrico pulsato che consente la riduzione della carica batterica e il controllo della crescita del biofilm.

AlfaCleaner is a thermal circuit cleaning system composed of two filtration stages: the first one is made up by a bag filter with a magnet (it can also be equipped with more magnets than one) with available filtrations of 1-5-10-25-50-100 microns, and a second stage composed of the revolutionary ARAGON filter which uses pulsed electric fields in water. The first stage captures all solid particles, including ferrous particles that adhere to the magnet, all deposits of limescale and biofilm that are continuously detached from the hydraulic circuit thanks to the action of the Aragon filter.

The ARAGON Filter is able to obtain the following effects: the conversion of Calcite, which forms limescales, into Aragonite nano-crystals, which do not aggregate into deposits. In fact, being crystals of considerable hardness they produce a scrubber effect on the entire circuit, cleaning it from encrustations and biofilm already present. All deposits and detached biofilm are continuously collected by the bag filter, while the water passing through the ARAGON filtration system is continuously filtered with the synergic action of the pulsed electric field which allows the reduction of the bacterial load and the control of the biofilm growth.

Caratteristiche tecniche:

Technical features:

Temperatura massima di esercizio <i>Max working temperature</i>	80 °C
Pressostato di sicurezza <i>Safety pressure switch</i>	yes – optional
Flussimetro per controllo portata <i>Flow meter for flow control</i>	yes - optional
Perdita di carico filtro pulito <i>Clean filter pressure loss</i>	0,1 bar
Pressione massima di esercizio <i>Maximum working pressure</i>	4 bar
Massimo volume filtrabile <i>Maximum filterable volume</i>	100 m ³ /h
Alimentazione elettrica <i>Power supply</i>	220-240-110 VAC

Dimensioni ingombro:

Overall dimensions:

Modello <i>Model</i>	Lunghezza <i>Length</i> mm	Larghezza <i>Width</i> mm	Altezza <i>Height</i> mm	Peso kg <i>Weight</i> kg
AWCL 855	855	550	1.300	80

RISULTATI VISIBILI VISIBLE RESULTS

Il sistema di filtrazione a sacco Alfacleaner con magnete cattura tutte le impurità presenti nei circuiti nei circuiti grazie all'azione di pulizia generata dal filtro ARAGON.

The Alfacleaner bag filtration system with magnet captures all the impurities present in the circuits thanks to the cleaning action generated by the ARAGON filter.



LA TECNOLOGIA ALFACLEANER NEL SETTORE OSPEDALIERO ALFACLEANER TECHNOLOGY IN THE HEALTHCARE SECTOR

Circuiti termosanitari: l'applicazione di Alfacleaner ai circuiti termosanitari permette l'utilizzo dell'acqua calda in maniera molto più sicura: il sistema dotato di filtro a sacco con filtro ARAGON oppure filtro automatico AVC con filtro ARAGON, permette la pulizia di tutto il circuito idraulico da depositi e biofilm fino alle utenze. Con Alfacleaner viene ridotta la presenza di microrganismi e l'acqua diventa più sicura.

Le foto di seguito illustrano una applicazione nel settore ospedaliero ove è stato installato uno skid costituito da filtro AVC e filtri ARAGON in side stream per la pulizia e controllo del biofilm delle acque potabili stoccate nei serbatoi in ingresso all'ospedale.

Per risolvere il problema di qualità dell'acqua calda sanitaria dell'ospedale sono stati installati due sistemi Alfacleaner modello ABG 45Z3 dotati di magneti con in uscita una serie di filtri ARAGON .

Thermal and sanitary circuits: the application of Alfacleaner to thermal and sanitary circuits allows for a much safer usage of hot water. The system, equipped with a bag filter with ARAGON filter or an automatic self cleaning filter AVC with Aragon filter, enables the cleaning of the entire hydraulic circuit from deposits and biofilm up to the end-users. With Alfacleaner, the presence of microorganisms is reduced, making the water safer.

The following photos illustrate an application in the hospital sector, where a skid consisting of an AVC filter and ARAGON filters in a side-stream configuration has been installed for the cleaning and biofilm control of potable water stored in the inlet tanks of the hospital.

Two Alfacleaner model ABG 45 Z3 systems, equipped with a magnet with a series of ARAGON filters at the outlet, were installed to solve the problem of water quality in the pipes coming from the hospital's pavillon.

Collettori ingresso/uscita:	DN 50
Materiale:	Acciaio inox AISI 304
Valvole IN/OUT/BYPASS:	DN 50 manuali
Valvola di drenaggio/scarico:	G1"
Alimentazione:	220V 50 Hz

Inlet/outlet manifolds:	DN 50
Material:	AISI 304 stainless steel
IN/OUT/BYPASS valves:	DN 50 manual
Drain/drain valve:	G1"
Power supply:	220V 50 Hz





APEF TECHNOLOGY

THE FIRST PATENTED FILTERS GENERATING A PULSED
ELECTRIC FIELD IN WATER
WITH CONTROL OF BIOFILM AND BACTERIA GROWTH
AND DE-SCALING FUNCTIONS

PATENTED



OUR LIFE DEPENDS ON WATER

Most of our body is made up of water.

Water is essential for our health: drinking water serves to keep our organs healthy and to replace the liquids we lose through breathing, sweat and digestion.



WHAY TO USE APEF?

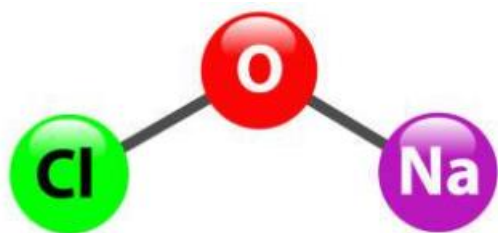
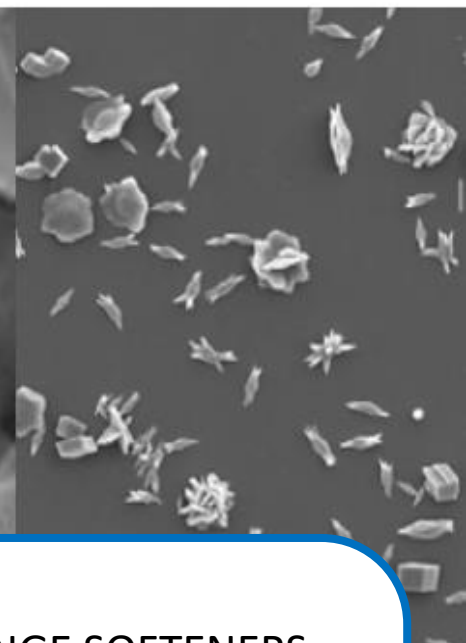
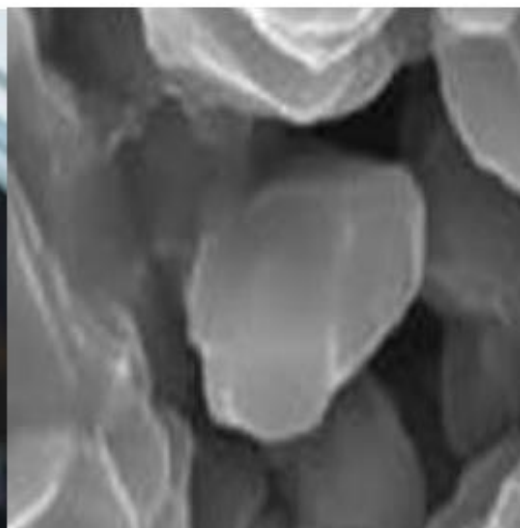

NO CHEMICALS TO DISINFECTS WATER



NO ION EXCHANGE SOFTENERS
AND WATER DEMINERALIZATION



APEF TECHNOLOGY: FILTER WITH PULSED ELECTRIC FIELD TO CONTROL THE GROWTH OF MICROORGANISMS

Microorganisms are deactivated through electroporation of the cell membrane.



APEF technology is effective for controlling the growth of various microbial communities in drinking water and also for *Legionella pneumophila*.



APEF TECHNOLOGY: PULSED ELECTRIC FIELD TRANSFORM CALCITE INTO ARAGONITE

NO SCALING

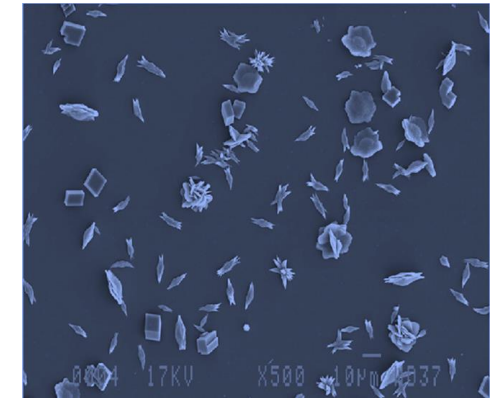
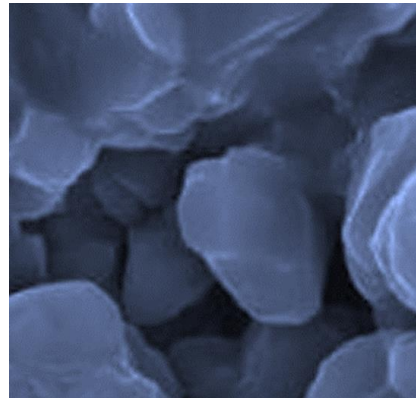

CALCITE GENERATE LIMESTONE

ARAGONITE CLEAN PIPELINE





APEF Integral Water is a technologically advanced and patented system, specifically designed for optimizing the quality of drinking water, both in civil and industrial contexts.

The distinction of this system lies in its antibacterial and anti-scaling properties, attributable to the use of Pulsed Electric Fields (PEF) Technology.

This technological solution allows APEF to provide water of a superior quality level.

The APEF system consists of two fundamental parts: an electronic control unit and a hydraulic unit, each with specific functions.

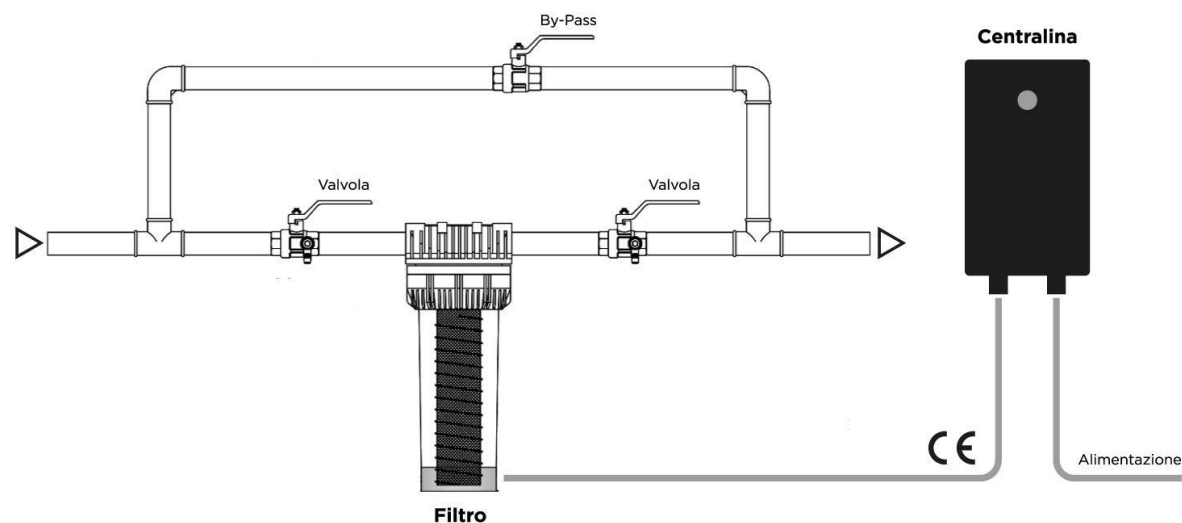

NOTHING WILL EVER BE THE SAME AGAIN

- APEF eco-sustainable technology

APEF FEATURES :

- APEF is eco-friendly: no use of chemicals
- APEF limits the risk of presence of bacteria, fungi, algae, legionella, etc
- APEF removes limescale deposits and prevents their formation by transforming calcium carbonate into aragonite.
- APEF allows for lower maintenance costs of thermo-sanitary systems.
- APEF maintains drinking water with its mineral salts: we call this water integral water
- APEF enables savings in the use of household detergents



AMORNMONGKOL Co.,Ltd.
38/91 Moo 19 Bangphli Yai,
Bangphli, Samut Prakan 10540
Tel. +662 114 3085 | Email info@amco.co.th
LINE [@amco](https://www.amornmongkol.com) | www.amornmongkol.com

